



North East Florida Woodturners

Volume 17 Issue 10 October 2017

An Affiliate of the American Association of Woodturners – Club Number 130 - jaxturners.org

President's Message

Although some in our area suffered significant damage from hurricane Irma, judging from the damage inflicted in other sections of our state I think everyone will agree we were very fortunate as it could have been much worse. I want you to know the decision to cancel our meeting last month was the unanimous decision of the club Board of Directors. While the decision to cancel the meeting on scheduled date of September 11 was a simple one due to the timing of the hurricane we decided against trying to reschedule the meeting because we anticipated many members would be without power for an unknown period of time and the post hurricane cleanup could be significant. After experiencing unique events such as a hurricane it is a good practice to reflect back on the experience and document "lessons learned" so that you are better prepared for the next time a similar event occurs. Having recently completed this activity I would like to share with you one of my "lesson learned". Be sure to add **Anchor Seal** to



your list of pre-hurricane supplies, you are certain need it.

In last month's letter I talked about the importance of improving our club through the involvement of all members. It is important that we continue this discussion through the remainder of this year. Please give some thought as to how you can increase your involvement in our club.

I want to give a big thanks to Paul Rushton for his demonstration in August on turning a small hollow vessel. If you want to refer to the steps Paul followed in his demonstration the detailed instructions are posted on our web site. Don't miss our October meeting, Keith Larrett will demonstrate turning an "End Grain Hollow Form".

I look forward to seeing you at the October meeting.

Safe Harbor – Kay Sievert

Due to the hurricane damage at Safe Harbor our classes have been stopped until further notice.

New Members – Paul Rushton

Keep spreading the word about our club. New members are one of our principal sources of revenue for the club!

Website – Keith Larrett

Nothing to report.

Treasurer – Kathy McCall

Come on stragglers dues are due!

Library – Liz Jensen-Forbell

The 2017 Florida Symposium discs are in for you to check out

Wood Raffle – Barbara Hahn

Don't be hoarding all that storm wood! Bring some in for the raffle!

Meeting Demos – Tina Minahan

We are coming close to the end of another great year. We would like to start early getting ideas from each of you on demonstrations that you would like to see in 2018. Would each of you kindly send me any email to Tminahan@hotmail.com with two items that you would like to see in 2018. I know that many of you do not feel that you are ready to do a demo in front of the group. I trust that each of you has an idea

COMMITTEE NOTES

or two of what you would like to see. I'd like to be able to prepare a list from your suggestions and pass it out at our November meeting. Please quickly jot down your ideas and send them to me right away so that I may begin preparing the list.

National Demos – Ed Malesky

I don't have anything about the demonstrations, but I have been in contact with the Jacksonville Zoo and they would like us back for ZooLights again this year. ED

Secretary – Don Penny

Remember! The Fair drop-off is the end of October! It is going to be a great show!

Demonstration

This month Keith Larrett will be demonstrating a small end grain hollow form like these.



WOODTURNERS CONTEST & EXHIBIT

Greater Jacksonville Agricultural Fair 12th Annual Wood Turners' Exhibit & Contest Chairman - Don Penny

The 12th Annual Wood Turners' Exhibit will be on display at the 62rd Annual Greater Jacksonville Agricultural Fair, Wednesday, November 1st through Sunday, November 12th.

The theme will be "Turned Objects" with entries accepted in two (2) categories:

1. Conventional Turned Object Category

This category is for unembellished, turned objects. The piece must be turned with no additional elements other than clear finish, if desired.

2. Embellished Object Category

This category is for those who wish to show their turning as an artistic expression. The primary portion of the piece must be turned, but may incorporate additional elements and finishes to express the theme.

Entries will be accepted on Sunday, October 30th, in Exhibit Hall "A" from 10:00 am to 2:00 pm. Exhibits will remain on display through the end of the fair, Sunday, November 12th. **Removal of articles may begin at 7:00 P.M. that evening.**

- Please complete a separate entry form for each entry you submit.
- Each entry must be the sole work of the entrant.
- It is preferred that the entry be created in response to the challenge of this contest, but pieces completed within the 12 months prior to entry are eligible.
- Wood must be the primary medium and the use of the lathe must be obvious.
- Contest promoters and/or sponsors are not responsible for late, incomplete, or misdirected entries.
- An entrant may submit a total of up to three (3) entries but may only receive a maximum of one prize per category. Please complete an entry form for each entry you submit. You may compete in both categories.
- The judges' decision will be final. Judging will be done by 4 judges judging both categories.

Traditional

Made up of artists in the wood craftsmanship community who will judge:

1. Quality of work, overall craftsmanship, and degree of difficulty
2. Design, form, originality, and overall execution of the piece
3. Quality of finish and is the finish appropriate for the piece
4. Wood selection and the use of the element of the selected wood

Embellished

Made up of artists not normally associated with wood craftsmanship who will judge:

1. Quality of work, overall craftsmanship, and degree of difficulty
2. Design, form, originality, and overall execution of the piece
3. Congruity of the piece
4. Use of elements to express the title of the piece.

Prizes In Each Category

First Prize - \$150.

Second Prize - \$100.

Third Prize - \$100

One Honorable Mention Prize will be awarded for best piece by a turner who started turning after November 2016 - \$50

Please Complete An Entry Form For Each Piece You Are Entering

You may complete the entry form below or when you bring your entry to the Jacksonville Fairgrounds, 510 Fairgrounds Place, Jacksonville, FL 32202, on **Sunday, October 30th**, between the hours of 10:00 am and 2:00 pm. A Fair Volunteer will be in Exhibit Hall "A" to assist you.

Articles may not be removed prior to 7:00 P.M., Sunday, November 12th.

GREATER JACKSONVILLE FAIR WOODTURNING CONTEST

Name: _____

Address: _____ City: _____

State: _____ Zip: _____ Phone: _____

E-mail _____

CATEGORIES: Conventional Turned Object: _____ Embellished Object: _____
New Turner: _____

Give a brief description of your entry including the type of wood and method used.

Shop Tips!

The Jam Chuck

This is the simplest device for reverse chucking: it is a wooden disk with a groove turned into it to match the diameter of the bowl. The bowl is reversed onto the disk and held in the groove by a snug fit, the groove serving also to center the bowl. The tailstock is brought up to help keep the piece in place. At low revolutions and with light cuts, the foot is shaped, leaving a small stub at the tailstock point. (See Figure 1.) This stub will finally be chiseled off and the spot sanded to blend in.

The wooden disk can be held via faceplate or screw chuck. It can be any material – plywood is just fine. One jam chuck disk is used per bowl, so you end up with a pile of disks on various diameters, but they can be reused with smaller-diameter bowls.

The tailstock support also works for irregular – or natural-edged bowls, when a foam-padded cone is used inside the bowl to jam against. (See Figure 2.) The cone is readily made from scrap wood to match the unique size and shape of the bowl; at its simplest it is the waste block left behind when the bowl is parted off. This approach is pretty straight-forward and works well.

~ Peter M. Smith

This item has been adapted from the article, "Introduction to Chucking," by Peter M. Smith, which appeared in the June 1995 issue of *American Woodturner*.

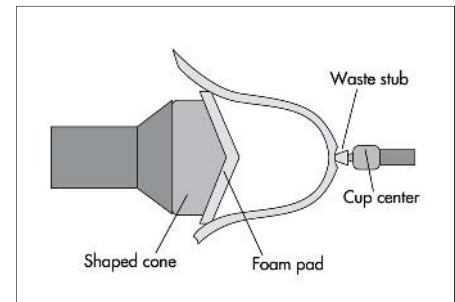
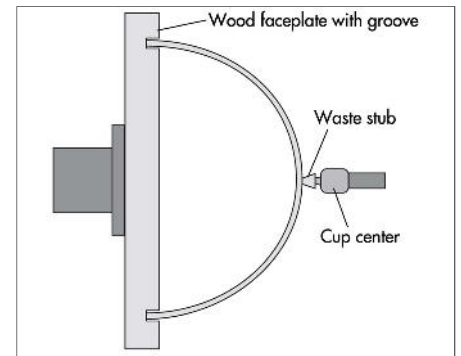

Better Success with Jam-Chucking

I've helped a few woodworkers who have had problems when turning with a jam chuck. This three-step process might help you be more successful.

Step 1: Turn a jam chuck with a small tenon that fits inside the bowl. Turn the outside diameter of the jam chuck so the diameter matches the outside diameter of the bowl.

Step 2: Fit the bowl over the tenon and apply pressure with the tailstock. For added security and antislip protection, wrap the joint between the bowl and jam chuck with masking tape.

Step 3: With the foot turned, leave the masking tape in place but back off the tailstock. Slow the lathe speed and turn away the nub. When removing the nub, use light cuts that apply pressure toward the center of the form and toward the headstock. Then sand the bottom.

~ Chris Wright

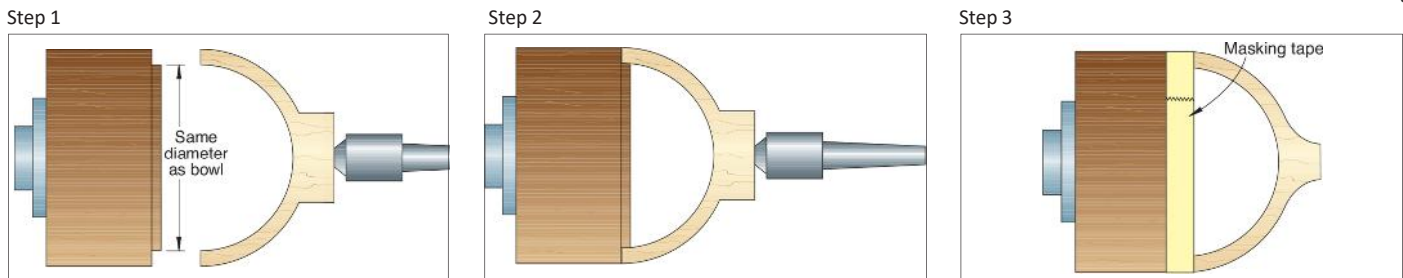

Total Experience Videos

The AAW has started a new video program where turning masters share their turning tips. This month Glenn Lucas shares his grinder techniques. Click the link and give it a try!

Total Experience video tip about grinder repair, featuring Glenn Lucas (TRT 4:09). Video link:
<http://www.woodturner.org/?page=TEVideoGrinderMaint>

Educational Opportunity Grants (EOG)

The application process is open for 2018 Education Opportunity Grants through December 31, 2017. Grants may be awarded to individuals, chapters, and schools and other groups for woodturning education endeavors. Learn more on the AAW website at:

<http://www.woodturner.org/?page=GrantsEOG>

Upcoming Events

October Meeting – October 9th 6pm – 9pm

Woodcraft of Jacksonville
11160 Beach Blvd #121
Jacksonville, FL 32246

Jacksonville Fair Drop Off and Delivery

Sunday October 30th 10am – 12pm
WoodCraft Parking Lot